

## SECTION 300

### FIRE SAFETY SYSTEMS

<b>301.00 FIRE SAFETY SYSTEMS- DEFINITIONS</b>	
301.00 Definitions	300-3
<b>302.00 FIRE SAFETY SYSTEMS- GENERAL POLICY</b>	
302.01 Fire Lanes	300-4
302.02 Underground Storm Water Management Facilities	300-4
302.03 Water Protection Lines	300-5
<b>303.00 FIRE SAFETY SYSTEMS- PLANNING AND DESIGN</b>	
303.01 Fire Lanes	300-5
303.02 Emergency Access in General	300-5
303.03 Emergency Access to Buildings	300-6
A. Front of Building	300-6
B. Rear and Side of Buildings	300-6
C. Emergency Access Limits	300-7
303.04 Emergency Medical Access to Swimming Pools	300-7
303.05 Underground Fire Lines	300-8
303.06 Fire Hydrants in General	300-9
303.07 Fire Hydrants relative to Buildings and Structures	300-10
303.08 Fire hydrants relative to Fire Sprinkler, Fire Sprinkler/Fire Standpipe, Fire Standpipe Fire Department Connections	300-10
303.09 Fire Sprinkler, Fire Sprinkler/Fire Standpipe, Fire Standpipe Fire Department Connections	300-11
303.10 Water Systems and Fire Flow Requirements	300-11
303.11 Water Storage Systems	300-12
303.12 Rural Water Supplies	300-12
<b>304 FIRE SAFETY SYSTEMS- SUBMISSION REQUIREMENTS</b>	
304.01 Site Plan Elements in General	300-13
304.02 Fire Lanes	300-13
304.03 Fire Sprinkler, Fire Sprinkler/Fire Standpipe, Fire Standpipe Fire Dept. Connections	300-13
304.04 Fire Flow Calculations	300-13
<b>305 FIRE SAFETY SYSTEMS- CONSTRUCTION STANDARDS</b>	
305.01 Fire Lanes	300-14
305.02 Access Control Gates, Barriers, and Storage Areas	300-15
305.03 Underground Fire Lines	300-16
A. Acceptance Testing	300-16
B. Underground Fire Line Anchorage	300-17

C. Fire Detection Check Valves	300-17
305.04 Fire Hydrants	300-17
305.05 Fire Sprinkler, Fire Sprinkler/Fire Standpipe, Fire Standpipe Connections	300-18
305.06 Rural Water Supply Access	300-18
305.07 Fire Sprinkler, Fire Sprinkler/Fire Standpipe, Fire Standpipe Fire Dept. Connections	300-18
<b>TABLES</b>	
Table 3-1 Building Height and Distance From the Curb or Emergency Access Point	300-7
Table 3-2 Use Group and Fire Hydrant Remote Distance	300-10
Table 3-3 Fire Flow Requirements for Single Family Detached and Two Family Dwellings	300-12
Table 3-4 Fire Lane Sign Lettering Size	300-15
Table 3-5 Water Flow Rate for Line Flushing	300-16
<b>FIRE SAFETY SYSTEMS - DETAILS</b>	
350.01 Typical Fire Hydrant	FH-1
350.02 Typical Fire Hydrant with Curb and Gutter or Ditch Line	FH-2
350.03 Typical Fire Hydrant Island and Parking Area	FH-3
350.04 Typical Fire Hydrant Vehicle Impact Protection	FH-4
350.05 Typical Fire Hydrant on Residential Street	FH-5
350.06 Emergency Access Space with Accessible Parking	EA-1
350.07 Typical Emergency Access Space	EA-2
350.08 Fire Line Detail	FL-1
350.09 Fire Line Detail	FL-2
350.10 Water Distribution System Detector Check Valve with 1" and 5/8"x3/4" Detector Meters	DCV-1
350.20 Detector Check Valve Vault Cross-sectional View	DCV-2
350.21 Typical Fire Department Connection Vault (4' Diameter)	VLT-1
350.22 Typical Remote Fire Department Connection Detail	FDC-1
350.30 Method of Strapping Fire Hydrant to Main	ST-2
350.40 Alternate Method of Strapping Valve to Hydrants with "Duc-lug"	DL-1

## SECTION 300 - FIRE SAFETY SYSTEMS

### 301.00 FIRE SAFETY SYSTEMS- DEFINITIONS

#### 301.00 Definitions:

- A. **Emergency Access Limit**- The maximum distance between a building or structure and the closest point of emergency vehicle access. The distance shall be measured from the main entrance of a building or structure to the edge of pavement, curb line, or emergency access point.
- B. **Emergency Access Point**- An emergency access point is defined as the closest point to the main entrance or structure that an emergency vehicle can reach on an all-weather surface capable of supporting an emergency vehicle.
- C. **Emergency Medical Service Access**- The provision made to allow Emergency Medical Service (EMS) vehicles and personnel to access a facility, building, or structure for EMS operations.
- D. **Fire Department Access**- The provision made to allow the Fire Department to access a facility, building, or structure for fire fighter operations.
- E. **Fire Apparatus Access Road**- An approved road that provides fire/rescue apparatus access from a fire station to a facility, building, or portion thereof. This is a general term inclusive of all other terms such as fire lane, public street, private street, parking lot lane and access roadways.
- F. **Fire Lane**- An approved road or other passageway developed to allow the passage of fire apparatus. A fire lane is not necessarily intended for vehicular traffic other than fire/rescue apparatus.
- G. **Fire Department Connection (FDC)** - An approved sprinkler, sprinkler/standpipe, or standpipe system appurtenance that permits a Fire Department apparatus to supplement water pressure to the suppression system where the FDC is physically attached to a building or structure.
- H. **Freestanding (Remote) Fire Department Connection**- An approved sprinkler, sprinkler/standpipe, or standpipe that permits a Fire Department apparatus to supplement water pressure to the suppression system where the FDC is detached (remote) from a building or structure.
- I. **Underground Breezeway Loop**- A section of sprinkler piping that connects one side of a building to another, typically underground and under a central exterior stairway of a building, such as a garden apartment building.
- J. **Underground Fire Line**- A section of underground water pipe, between a water main and a fire suppression system that supplies water to a fire protection system.

## **302.00 FIRE SAFETY SYSTEMS - GENERAL POLICY**

### **302.01 Fire Lanes:**

- A. The Fire Marshal's Office shall designate fire lanes on private or public streets and private property used for residential, commercial, institutional, and industrial developments.
- B. The purpose of fire lanes shall be to prevent parking and standing adjacent to fire hydrants, access points to a building or structure, and to provide clear emergency access to buildings, structures, and fire protection equipment.
- C. A minimum of two (2) signs, one type "A" and one type "C", shall designate fire lanes, one (1) at each end. Additional signs, type "B", shall be provided at a minimal interval of one hundred (100) feet. Fire lanes may be painted in parking areas where no curb or gutter exists and where posting of a metal sign is not feasible.
  - 1. In lieu of type "B" signs curbing shall be painted yellow with "Fire Lane" stenciled in minimum four (4) inch letters, black in color, at a minimum of fifty (50) foot intervals on the curbing.
  - 2. For short sections of a fire lane, of less than fifty (50) feet in length, and the entire length of the fire lane is clearly visible, a single type "B" sign may be used as approved by the Fire Marshal's Office.
- D. Site plans for fire lanes shall be submitted to the Fire Marshal's Office for approval before being installed.
- E. All site and subdivision plans shall have a fire lane plan included as part of the Prince William County Land Development site/subdivision plan approval process to allow the Fire Marshal's Office to conduct a fire lane needs assessment. Fire lanes shall be shown on the plan and the scale of the plan be not less than 1" = 30'. Street names and building addresses shall also be shown on the plan. Submitted plans shall also indicate designated fire lanes are to meet the criteria of the Prince William County Fire Prevention Code.
- F. Site plans for existing fire lanes shall be submitted to the Fire Marshal's Office for approval before being installed. For projects where site plans are not required fire lanes will be designated at the request of the property owner, or agent, if conditions warrant. The owner will be required to submit a scaled site plan drawing for fire lane designation to the Fire Marshal's Office for review and approval. All fire lane information shall be applied in a clear and orderly manner to the plan.
- G. See Section 305.01 in the construction standards for additional requirements for fire lanes.

### **302.02 Underground Storm water Management Facilities:**

- A. Unless otherwise approved by the Fire Marshal, storm water management facilities shall not be located underneath fire lanes.

- B. All underground storm water management facilities within a distance of one hundred (100) feet to the exterior perimeter wall of a building or structure shall be marked for visual identification in a manner acceptable to the Fire Marshal.

**302.03 Water Supply Systems:**

- A. All water supply systems shall be provided in accordance with Section 400 of this manual.
- B. See Section 305.03 in the construction standards for additional requirements for underground fire lines.

**303.00 FIRE SAFETY SYSTEMS- Planning and Design**

**303.01 Fire Lanes:**

- A. Fire lanes in residential, commercial, institutional, and industrial developments shall be designated by the Fire Marshal’s Office, and be a minimum of twenty (20) feet in clear width. The width shall be measured perpendicular from the painted curb or perimeter line. Parking and traffic flow patterns within a designated fire lane shown on site plans shall be as follows:

<b>STANDARD REQUIREMENTS</b>	
<b>Width Curb to Curb</b>	<b>Parking Condition</b>
less than 28’	No parking permitted on either side of street
28’ to 36’	Parking permitted on one side as determined by the Fire Marshal’s Office
36’ or greater	No fire lane will be established

**303.02 Emergency Access in General:**

- A. Approved Fire and /Rescue access shall be provided for every facility, building, or portion of a building.
- B. Fire apparatus access roads shall be capable of supporting a minimum of eighty thousand (80,000) pounds vehicular load, have a minimum width of twenty (20) feet, a minimum vertical clearance of at least thirteen feet six inches (13’6”), a maximum vertical projection of eight (8) inches, and be able to accommodate the turn characteristics of a forty-five (45) foot long truck.
- C. Where fire apparatus access roads cross underground water cisterns, parking garages, or similar facilities, design calculations shall be provided by a professional engineer which show that the travel way or parking deck of the garage is designed for a eighty thousand (80,000) pound vehicle weight load and outrigger pads for a ladder truck or

tower ladder that is designed for a nominal four hundred and fifty (450) lbs/sf uniform live load.

- D. All underground storm water management facilities, within a distance of one hundred (100) feet to the exterior perimeter wall of a building or structure, shall be marked for visual identification in a manner acceptable to the Fire Marshal.
- E. All weather Fire Apparatus access roads to construction and demolition sites shall be provided during the time of construction or demolition of a building. These requirements are not applicable to driveways serving single family dwellings. The access road need not be paved or graveled, but must be able to meet the following criteria:
  - 1. Such roadways shall be readily accessible to emergency and inspection staff vehicles.
  - 2. Complies with Section 303.02B.
  - 3. Such roadways shall not be blocked or obstructed by vehicles, construction equipment, or construction materials.
- F. Such roadways in excess of one hundred fifty (150) feet with a dead end must be provided with an approved emergency apparatus turn-a-round.
- G. Access control Gates, Barriers, and Storage areas, when provided on private streets, shall be designed, installed and located in a manner approved by the Fire Marshal's Office. Access control gates and all accessory facilities and equipment shall not be permitted to be in the public right-of-way.
- H. All electronically operated access control gates shall be operable for entry and exit by a manner approved by the Fire Marshal's Office.
- I. See Section 305.02 in the construction standards for additional access control gate and storage area requirements.

### **303.03 Emergency Access to Buildings:**

#### **A. Front of Building-**

- 1. An unobstructed emergency access space of at least nine (9) feet in width shall be provided in front of the main entrance of buildings or structures where vehicle parking is adjacent to the building and not separated by a fire lane.
- 2. Where there are multiple tenants, having separate exterior main entrances in a building or strip shopping center, a series of nine (9) foot wide unobstructed emergency spaces shall be provided on the front side where parking is adjacent to the building and not separated from it by a fire lane. The spaces shall be provided at maximum one hundred (100) foot intervals along the front of the building.

#### **B. Rear and Side of Buildings-**

- 1. Access requirements shall comply with the appropriate parts of Part 401 of the Prince William County Zoning Ordinance.
- 2. All portions of a building or structure and any portion of the exterior wall of the first story of a building or structure shall be within one hundred fifty (150) feet of an approved access road capable of supporting fire and rescue apparatus. In addition

the access provided exclusively for emergency purposes shall be a minimum of twenty (20) feet in width.

3. Where access cannot be provided within one hundred fifty (150) feet of an approved access road capable of supporting fire/rescue apparatus due to location on the property, topography, waterways, non-negotiable grades, slopes, or other similar conditions, distance may be increased provided an approved alternative means of fire protection is provided.

**C. Emergency Access Limits-**

1. In single-family developments, the maximum distance from the curb line, or emergency access point, to the building or structure entrance shall not exceed seventy-five (75) feet.
2. In multi-family developments, the maximum distance from the curb line, or emergency access point, to the building or structure entrance shall not exceed fifty (50) feet. The maximum number of buildings or structures connected in series shall be limited to two (2), unless fire/rescue vehicles have approved access to the front and back of the building or structure.
3. In buildings or structures over three (3) stories in height, the maximum distance from the curb, or emergency access point, shall conform to the guidelines listed in Table 3-1. For purposes of this section, the building or structure height measured in feet is the distance between the lowest level of fire department access to the finish floor level of the topmost habitable floor.

<b>Table 3-1</b>	
<b>BUILDING HEIGHT AND DISTANCE FROM CURB OR EMERGENCY ACCESS POINT</b>	
<b>Building height (feet)</b>	<b>Distance (feet)</b>
30-45	50
46-60	40
61-75	30
Greater than 75	20

**303.04 Emergency medical access to swimming pools:**

- A. Emergency medical access shall be provided to within fifty (50) feet of the edge of public swimming pools by provision of a minimum ten (10) foot wide vehicular access lane capable of supporting 24,000 pounds. The access lane shall be posted as a “Emergency Access Only” lane. In addition the path of travel from the end of the vehicle access to the physical pool location shall:
  1. Have a clear height of eight (8) feet vertically.
  2. Have a clear width of not less than four (4) feet.

3. Be free of steps and where there is a difference in grade between the pool and the vehicle access a ramp with a maximum slope of 1:12 shall be provided.
4. A minimum eight (8) foot wide personnel gate shall be provided in any pool security fence.

### **303.05 Underground Fire Lines:**

- A. All underground fire lines shall be privately owned and maintained.
- B. All underground fire lines shall be a separate connection to the water main unless otherwise directed by the appropriate water purveyor (Prince William County Service Authority, Virginia American, etc.).
- C. Underground fire lines shall have a valve at its point of connection to the water main servicing it.
- D. Detailed plans for underground fire lines and a fire protection permit application shall be submitted to Development Services for approval prior to installation. Profiles of the underground fire line are optional but are recommended.
- E. Underground fire lines for fire sprinkler, fire sprinkler/standpipe, or fire standpipe systems shall be installed such that the underground line terminates in a riser room located immediately adjacent to an exterior wall with a personnel door, permitting immediate access to the main fire sprinkler, fire sprinkler/fire standpipe, or fire standpipe control valves, located in the riser room for use by Fire/Rescue personnel.
- F. Underground fire lines shall extend horizontally a minimum of twenty-four (24) inches, but not more than ten (10) feet, into a building or structure beyond the exterior wall of the building or structure.
- G. Underground fire lines shall be a minimum of six (6) inches in diameter unless hydraulic calculations are provided, and approved by the Fire Marshal's Office, documenting that a smaller diameter fire line will provide the pressure and flow demands of the fire protection system it serves. All hydraulic calculations shall be prepared, sealed, and signed by a professional engineer.
- H. Underground fire lines must have forty-two (42) inches of compacted soil cover depth.
- I. Underground fire lines must maintain a perimeter clear of other utilities and other non-compacted soil for a minimum of thirty-six (36) inches around the pipe.

#### **Exceptions:**

1. In cases where this clear area is not possible and/or the forty-two (42) inches of cover is not possible, supplemental insulating measures to keep pipe exposure from temperatures below forty (40) degrees Fahrenheit as referenced in detail 350.09 shall be utilized. (NOTE: A minimum of thirty-six (36) inches depth of cover must be maintained per code.) However, if the depth of cover for the fire line is sixty (60) inches or greater, from the finished grade, the thirty-six (36) clear area may have other fill material and be crossed by any utility, except in cases where the utility is open to the atmosphere. (Example: Storm water management and/or roof drain lines) In that case supplementary insulation measures shall be utilized.
2. Supplementary insulation measures permitted by the Fire Marshal's Office include extruded polystyrene (XCCPS), suitable for underground burial and the density to



reduce compaction. (Example: Kingspan Greenguard XPS). Material data sheets must be submitted with the design/engineering plans and showing profiles and details in how it is to be installed. Other insulation measures may be permitted but will be subject to approval of the Fire Marshal's Office. The Designer or Engineer must provide material safety data sheets that clearly indicate the material being used and its suitability from the manufacturer for this application. In either case, the designer or engineer must demonstrate that the amount of insulation installed meets the required geothermal criteria. (Example: 1" of insulation will equate to the amount of missing soil to provide adequate thermal protection for the fire line at or above 40 degrees Fahrenheit.)

- J. See construction standards section 305.03 for additional requirements for underground fire lines.

**303.06 Fire Hydrants in General:**

- A. Fire hydrants shall be located along the right-of-way, at street intersections, and at intermediate locations where necessary as determined by the Fire Marshal's Office in cooperation with the water purveyor.
- B. All distance measurements shall be made along the centerline of streets, travel ways, or other unobstructed paths that may be used by the fire department. In no case shall the distance between fire hydrants exceed one thousand (1,000) feet.
- C. In areas with curb and gutter, the center of the fire hydrant shall be located a minimum of not less than eighteen (18) nor more than a maximum of thirty-six (36) inches from the face of the curb. No part of a fire hydrant shall cause conflict with, or overhang, a sidewalk, trail, or vehicular travelway.
- D. On roads with ditches, fire hydrants shall be located behind the ditch, but not more than ten(10) feet from the edge of the roadway.
- E. Traffic bollards, or other approved protective measures, shall be provided in areas such as parking lots where the proposed site improvements will not provide adequate vehicle impact protection of the fire hydrant from vehicles.
- F. When installed in parking areas, clear access shall be provided to the front of the fire hydrant (4-1/2" connection side) and fifteen (15) feet to each side. This clear access area shall be marked as a fire lane. If the hydrant is being installed in an island the clear access to each side may be reduced to three (3) feet. (See detail 350.03)
- G. A minimum distance of four and one-half (4-1/2) feet shall be provided from the centerline of a fire hydrant to plantings or other obstructions.
- H. Whenever possible, fire hydrants installed on streets, adjacent to driveways, shall be located a minimum of four and one-half (4-1/2) feet from the curb return (see Detail 350.05) on the driveway to the centerline of the fire hydrant. This distance shall be measured from the beginning of the curb return on the driveway to the centerline of the fire hydrant.

**303.07 Fire Hydrants relative to Buildings and Structures:**

- A. Fire hydrants shall be located to provide fire protection to remote areas of buildings and structures. Fire hydrants used to provide the minimum fire flow requirements shall be located within five hundred (500) feet of the building or structure to be protected.
- B. Fire hydrants shall be provided along the perimeter of a building or structure for use groups in accordance with Table 3-2. The remote distance shall be measured from the centerline of the fire hydrant to the most remote point the hydrant will serve.
- C. Fire hydrants shall be a minimum of fifty (50) feet from all buildings and structures including townhouses except single family detached dwellings.
- D. A fire hydrant may be required, as determined by the Fire Marshal’s Office, to be placed within five hundred (500) feet of all pipestem building lots.

<b>Table 3-2</b>	
<b>Use Group and Fire Hydrant Remote Distance</b>	
<b>Use Group</b>	<b>Remote Distance (feet)</b>
<b>F, H, S, U</b> Industrial and storage buildings	300
<b>E, I</b> Educational and Institutional buildings	300
<b>A, B, M</b> Assembly, Business, and Mercantile buildings	300
<b>R1, R2, R3, R4</b> Motels/Hotels, multi-family apartments and condominiums, and single-family attached dwellings	300
<b>R5</b> Single-family detached dwellings	500

**303.08 Fire Hydrants relative to Fire Sprinkler, Fire Sprinkler/Fire Standpipe, Fire Standpipe Fire Department Connections:**

- A. Fire hydrants shall be located within a travel distance of one hundred (100) feet of any fire department connection where a Fire Sprinkler, Fire Sprinkler/Fire Standpipe, Fire Standpipe fire protection is required in a structure or buildings according to the Building Code.
- B. Where possible the fire hydrant designated to serve a fire department connection shall be located on the same side of the street or travel way as the fire department connection.
- C. Where possible the fire hydrant designated to serve a fire department connection shall be in clear and plain view of the fire department connection it serves.

**303.09 Fire Sprinkler, Fire Sprinkler/Fire Standpipe, Fire Standpipe Fire Department Connections:**

- A. Fire Department Connections (FDC) shall be located to be readily visible from the street and on the front side of the building in a location approved by the Fire Marshal's Office. If a visible location from the street is not possible, alternative locations shall be approved by the Fire Marshal's Office.
- B. Fire Department Connections shall be located to provide immediate access for fire department use. Walls, fences, trees, shrubs, and other obstructions shall not be within three (3) feet of the FDC and not obscure or prevent access.
- C. Fire Department Connections shall be designed to allow the use of any one (1) FDC to serve all the sprinklers within the building or structure, and allow the use of any one (1) fire sprinkler/fire or fire standpipe FDC to serve all the standpipes within the building or structure unless approved by the Fire Marshal's Office.

**303.10 Water Systems and Fire Flow Requirements:**

- A. Water Systems shall be designed to provide fire flows in accordance with Table 3-3, plus the maximum daily domestic demand required by the water purveyor. At least one (1) point within five hundred (500) feet of each building proposed to be serviced shall have a residual pressure of not less than twenty (20) pounds per square inch (psi).
- B. The fire flows shown in Table 3-3 apply to new development. Where the size and scope of the development exceeds these requirements, additional fire flow shall be provided in accordance with Insurance Service Office (ISO) requirements.
- C. Fire flow requirements may be met in single family residential and two family developments with a single fire hydrant within five hundred (500) feet of a structure in accordance with Table 3-3.
- D. In areas of multi-use development, the higher fire flow rates listed above shall be provided for each hydrant.
- E. Other residential, commercial, educational, assembly, business, mercantile, motel/hotel, multi-family apartments and condominiums, institutional, storage, and industrial developments shall provide a fire flow of a minimum of two thousand five hundred (2,500) gallons per minute (gpm).
- F. Fire Flow Calculations-
  - 1. Fire flow calculations shall include assumptions about the existing water system. The calculations shall indicate the available fire flows at the proposed fire hydrants and the pressure throughout the proposed system. Calculation of available fire flow shall be based on actual fire flow test data or modeled hydraulic data provided by the water purveyor, that is less than one year old.
  - 2. Fire flow calculations for projects to be developed in sections of phases shall indicate the available fire flow during each section of phase of the project.

3. For small sites that propose no major waterline extensions , an evaluation of the existing available fire flow may be substituted for existing fire flow calculations.
4. In the event that minimum fire flows cannot be achieved, the developer of the property shall design additional fire protection measures into every building not covered by adequate fire flows. Any deviation from the minimum fire flow requirements shall require a site development plan waiver application, for conditional fire flow requirements. See site development plan required in Section 304.03 for additional information.
5. Fire flow calculation shall be prepared using a computer program that is acceptable to the water purveyor, such as the Water CAD distribution modeling program or comparable.
6. Fire flow calculations shall utilize a pipe roughness factor,  $c=120$ , for pipes that are twelve (12) inches in diameter or greater. For pipes smaller than twelve (12) inches in diameter, a roughness factor,  $c=100$ , shall be utilized. Since a conservative “ $c$ ” factor is utilized for the calculations, no allowance is required for the losses in valves and other fittings.
7. The line velocity shall not exceed ten (10) feet per second (fps) under any flow condition. However, the line velocity may be permitted to exceed ten (10) feet per second (fps) as deemed appropriate by the water purveyor.

<b>Table 3-3</b>		
<b>Fire Flow Requirements for Single Family Detached and Two-family Dwellings</b>		
<b>Unit to Unit Exposure Distance (feet)</b>	<b>Flow Requirements per Hydrant (GPM)</b>	<b>Flow Requirements for a Hydrant with 500 feet of a structure (GPM)</b>
0 to 10	1,500	2,000
>10 to 30	1,000	1,500
>30	1,000	1,000

**303.11 Water Storage Systems:**

- A. Water storage systems utilized to maintain fire flow shall have the capacity to sustain the required flow for a minimum of four (4) hours.

**303.12 Rural Water Supplies:**

- A. Suitable static water sources such as storm water management or BMP wet ponds in areas beyond the limits of public water services shall be accessible to fire department pumpers. Access to static water sources may include dry suction hydrants and/or access lanes capable of supporting heavy fire apparatus under all weather conditions.
- B. The location and method of access shall be approved by Public Works and shall be constructed in accordance with Section 305.05 of this manual.

## **304 FIRE SAFETY SYSTEMS – SUBMISSION REQUIREMENTS**

**304.01 Site Plan Elements in General:** Site development plans shall include the following:

- A. Fire Lane designation
- B. Emergency access
- C. Existing and approved fire hydrants
- D. Fire protection lines
- E. Water storage systems, where applicable.
- F. Rural water supplies, where applicable.

**304.02 Fire Lanes:**

- A. Site plans for fire lanes shall be submitted to the Fire Marshal's Office for approval before being installed. For projects where site plans are not required fire lanes will be designated at the request of the property owner, or agent, if conditions warrant. The owner will be required to submit a scaled site plan drawing for fire lane designation to the Fire Marshal's Office for review and approval.
- B. Fire lanes shall be shown on the plan and the scale of the plan be not less than 1" = 30'.
- C. Street names and building addresses shall also be shown on the plan. Submitted plans shall also indicate designated fire lanes are meet the criteria of the Prince William County Fire Prevention Code.
- D. All fire lane information shall be applied in a clear and orderly manner to the plan.

**304.03 Fire Sprinkler/Fire Sprinkler/Standpipe/Fire Standpipe Fire Department Connections:**

- A. The remote fire department connection shall be shown on the site development plan for the building or structure.
- B. A detailed drawing showing the length, size, and type of piping and appurtenances to be used as well as any changes in direction or elevation of the piping.
- C. Product sheets for piping, appurtances, and FDC shall be submitted for review and approval.
- D. The slope of the FDC piping shall be verified by a submission of an engineering report showing the elevation of the FDC piping at twenty foot (or portion thereof) intervals as installed in the field. The direction of the slope shall be shown on the FDC piping plan submission.

**304.04 Fire Flow Calculations:**

- A. Fire flow calculations shall be included with site development plans.
- B. Fire flow shall be shown at 20 p.s.i. residual pressure.
- C. Deviations from the minimum fire flow requirements in Section 302.10 of this manual shall a conditional fire flow waiver with the site development plan application. The

waiver shall address the current fire flow available and provide a water system analysis to determine the measures for bringing deficiencies up to minimum standards.



- D. Development Services, after coordination with the Fire Marshal's Office, shall approve additional fire protection measures proposed for every building not covered by adequate fire flows, prior to the approval of the site development plans. Any waivers will be coordinated with the water purveyor.
- E. Underground fire lines shall be reviewed for general conformance only, to include location and materials of construction. Sizing of the fire protection line shall be the responsibility of the design engineer and shall be in accordance with the requirements of the sprinkler manufacturer.

### **305 FIRE SAFETY SYSTEMS – CONSTRUCTION STANDARDS**

#### **305.01 Fire Lanes:**

- A. Fire lane signs shall be constructed of metal with a dimensions of approximately twelve (12) inches by fifteen (15) inches.
- B. The sign shall be painted with red letters on a white background with a three-eighths (3/8) inch red trim strip around the entire outer edge of the sign. The lettering on the sign shall read "NO PARKING OR STANDING FIRE LANE", which shall be spaced on the sign face uniformly. Solid arrows shall also be painted on the signs to point to and indicate the designated fire lane. The lettering and arrow on the sign shall be in accordance with Table 3-4.
- C. Signs for fire lanes shall be posted at intervals of a maximum of one hundred (100) with the bottom of the sign no less than six (6) feet from the ground and the top no more than eight (8) feet above the ground unless otherwise directed by the Fire Marshal's Office.
- D. Sign posts shall be metal and securely mounted unless approval from the Fire Marshal's Office is obtained prior to installation for an alternative method.
- E. When curbing is provided adjacent to the fire lane, it shall be painted yellow within the limits of the fire lane.
- F. When curbing is not provided adjacent to the fire lane, a two (2) inch wide yellow line shall be painted on the pavement at the edge of the paved surface. A two (2) inch wide second parallel yellow line shall be painted two (2) feet from the first line. These two lines shall be connected by two (2) inch wide diagonal lines at three (3) foot intervals or as approved by the Fire Marshal's Office.
  - 1. Where there is not a curb and it is impractical to install a metal sign in the fire lane area "NO PARKING OR STANDING FIRE LANE" in letters of at least two (2) feet in height may be painted when approved by the Fire Marshal's Office.

- G. Type “A”, “B”, and “C” fire lane signs shall be mounted as to be parallel to the travel way. Type “D” signs may be mounted perpendicular to the curb provided two signs are mounted back to back on the same post.

<b>Table 3-4</b>			
<b>Lettering</b>		<b>Letter Height (inches)</b>	
NO PARKING OR STANDING FIRE LANE Arrows		2 1 2 2-1/2 1	
<b>Sign Types and Design</b>			
Sign Type “A”	Sign type “B”	Sign type “C”	Sign type “D”
NO PARKING OR STANDING FIRE LANE 	NO PARKING OR STANDING FIRE LANE 	NO PARKING OR STANDING FIRE LANE 	NO PARKING OR STANDING FIRE LANE
Standard wording with a directional arrow at the bottom pointing right. One sign mounted parallel to the line of curbing or pavement edge at the end of the painted area.	Standard wording with two directional arrows at the bottom pointing right. One sign mounted parallel to the line of curbing or pavement edge at the middle of the painted area.	Standard wording with a directional arrow at the bottom pointing right. One sign mounted parallel to the line of curbing or pavement edge at the end of the painted area.	Standard wording with no directional arrows at the bottom. Two signs mounted back to back and perpendicular to the line of curbing or pavement edge at the middle of the painted area.

**305.02 Access Control Gates, Barriers, and Storage Areas:**

- A. All electrically operated gates and barriers operated for entry and exit shall be operated by a manner approved by the Fire Marshal’s Office and comply with the following:
1. All electrically operated gates shall be UL 325 compliant.
  2. There shall be an approved key override switch and approved radio operated controller for each gate.

Exception: Radio controlled exits may be waived by the installation of a “free exit” loop.

3. All electrically activated gates shall have Click to Enter (C2E) installed and maintained for Emergency Access.
- B. Gates requiring radio-controlled exit activation shall be provided with an approved two (2) inch by two (2) inch blue, reflective marking visible to the exiting vehicle. It shall also be located in the center of the gate.
- C. Electrically operated gates shall fail to the open position when the power is off and remain open until the power is restored.
- D. Access control gates shall have a clear width of not less than twenty (20) feet.
- E. Gates shall be of a swinging or horizontal sliding type.

**305.03 Underground Fire lines:**

**A. Acceptance testing:**

1. Acceptance testing shall be required of all underground fire lines prior to concealment and use. Underground fire lines, except those serving single-family detached and two family dwellings, shall be hydrostatically tested at not less than two hundred (200) pounds per square inch (psi) for two (2) hours or at fifty (50) psi in excess of the maximum static pressure when the maximum static pressure is in excess of one hundred fifty (150) psi.
2. Concealment of an underground fire line prior to acceptance testing may occur if a visual inspection of the line is conducted, by the Fire Marshal's Office, to verify that the piping and anchorage is installed in an approved manner, and if the developer or contractor assumes responsibility for corrections to failures of the hydrostatic test.
3. Flushing of an underground fire line shall occur prior to admittance of any water through the underground fire line and into the fire protection system it serves. The minimum water flow required for underground fire line flushing shall comply with Table 3-5 or the hydrostatically calculated water demand rate of the system, whichever is greater.
4. Hydrostatic testing of the underground fire line from the valve at the water main up to, and including, the temporary flange/gate valve assembly.

<b>Table 3-5</b>		
<b>Water Flow rate for underground fire line flushing*</b>		
<b>Pipe Size (inches)</b>	<b>Flush Orifice Size (inches)</b>	<b>Flow Rate (GPM)</b>
2	2	60
4	3	400
6	4	750
8	4	1,000
10	6	1,500
12	6	2,000



\*Remote fire department connections lines between the fire department connection and the point of connection to the fire sprinkler, fire sprinkler/fire standpipe, fire standpipe, and underground breezeway loops for sprinkler systems shall be flushed at the rates shown in Table 3-5.

**B. Underground Fire Line Anchorage:**

1. Pipe anchorage shall be required on underground fire lines wherever they change direction. This includes bends, tees, and pipe ends. The pipe shall bear on a surface, which is capable of resisting the loads imposed by moving water.
2. Restraining systems shall comply with the standards of the appropriate water purveyor.

**C. Fire Detection Check Valves:**

1. Approved detection check valves shall be required on all fire service mains in buildings served by a "wet pipe" type sprinkler system.
2. The detection check valve shall be equipped with a bypass meter assembly as shown in the details in Section 350.10 (DCV-1) of this manual. An appropriately sized gate valve shall be installed on either side of the check valve.
3. The vault housing the detector check valve should be sized in accordance with the details in Section 350/20 (DCV-2) of this manual.
4. Detection check valves shall not be required on exterior underground fire lines unless otherwise directed by the water purveyor.
5. An approved back flow preventer shall be required on all underground fire lines.

**305.04 Fire Hydrants:**

- A. Fire hydrants shall be connected to a water main with a minimum six (6) inch ductile iron pipe and shall be controlled by an independent six (6) inch gate valve. The gate valve shall be located as near to the water service main as possible.
- B. Where the hydrant service line is longer than fifty (50) feet, a second six (6) inch gate valve shall be located not more than six (6) feet from the fire hydrant.
- C. All hydrant barrels shall be painted in accordance with the water purveyor's Standards Manual.
- D. The four and one-half (4-1/2) connection pumper connection on the fire hydrant shall face the street, travel lane, or service drive.
- E. The bottom of the four and one-half (4-1/2) inch pumper connection shall be a minimum of eighteen (18) inches above the elevation of the edge of the shoulder on streets without curb and gutter and eighteen (18) inches above the elevation of the curb on streets with curb and gutter.
- F. The two and one-half (2-1.2) inch pumper connections on the fire hydrant shall have a minimum of four (4) feet clearance on all sides.
- G. All fire hydrants shall be traffic model type, either Mueller Centurion, Kennedy K-81, or an approved equal.

- H. Fire hydrants shall be of the compression type with main valve openings not less than five and one-quarter (5-1/4) inches in diameter. Hydrants shall have a cast iron body with bronze trim and shall withstand a hydrostatic pressure of three hundred (300) pounds per square inch (psi).
- I. Fire hydrants shall have a minimum six (6) inch base for setting, with a minimum of forty-two (42) inch cover on the connecting pipe.
- J. Fire hydrants shall be equipped with three (3) hose connections. Two (2) of the hose connections shall be two and one-half (2-1/2) N.S.T. and the third connection shall be four and one-half (4-1/2) inches N.S.T..
- K. Fire hydrants shall have a standard one and one-half (1-1/2) inch pentagon shaped operating nut, opening counter-clockwise. The direction of the opening shall be clearly marked by an arrow case on the outside of the hydrant.
- L. Fire hydrant connections to the water main shall be six (6) inch ductile cast iron pipe.
- M. Fire hydrant barrel paint shall be Duron #3837-6, chrome yellow, or equal.

**305.05 Fire Sprinkler, Fire Sprinkler/Fire Standpipe, Fire Standpipe Connections:**

- A. All fire department connections shall be fitted with N.S.T. connections.
- B. Wherever fire department connections are not readily visible from the street an "FDC" sign shall be installed. Such signs shall be a minimum of eighteen (18) inches on each side, red with reflective white letters, and mounted on point. The letters shall be of minimum three-quarter (.75) inch stroke and four (4) inch height. Arrows of minimum one-half (1/2) inch stroke shall be used to indicate the location of the FDC.

**305.06 Rural Water Supply Access:**

- A. Access to a static rural water supply shall be constructed in accordance with the design criteria found in NFPA Standard 1142.

**305.07 Fire Sprinkler/Fire Sprinkler/Standpipe/Fire Standpipe Fire Department Connections:**

- A. Fire Department Connections shall not be less than eighteen (18) inches nor more than forty two (42) inches in elevation above ground level measured from ground level to the centerline of the FDC connection inlets.
- B. In buildings classified as high rise by the building code, the FDC shall be located a minimum of fifty (50) feet away from the building or structure and be installed in accordance with the requirements for remote fire department connections.
- C. The location of FDC's shall be approved by Development Services and the Fire Marshal's Office and located as shown on the site development plan.
- D. Remote FDC's for high rise and other buildings shall be approved by the Fire Marshal's Office and comply with the following requirements:
  1. The check valve for the FDC shall be located inside the sprinkler room or and connect to the sprinkler system as required by the applicable edition of NFPA 13.
  2. The piping shall be restrained as required by the applicable section of NFPA 13.

3. The piping connecting the FDC to the fire sprinkler/fire sprinkler/standpipe/fire standpipe system shall be sloped to an automatic drip valve drain capable of draining the entire length of the piping. Where the automatic drip valve cannot be installed inside the conditioned space of the building, it shall be located in a vault complying with the requirements shown in drawing 350.22 to allow access to the drain for maintenance and to drain properly.
4. The vault for the FDC shall be provided with a floor drain to allow the vault to completely drain.
5. The FDC piping shall have at least forty-two (42) inches of earthen cover over the top of the pipe.
6. The FDC piping shall be hydrostatically tested at a minimum pressure of 200 p.s.i. for two (2) hours prior to being covered per NFPA 13.
7. The FDC and associate piping shall be flushed in accordance with the applicable edition of NFPA 13.
8. All fire department connections shall be fitted with N.S.T. connections.
9. Wherever fire department connections are not readily visible from the street and "FDC" sign shall be installed. Such signs shall be a minimum of eighteen (18) inches on each side, red with reflective white letters, and mounted on point. The letters shall be of minimum three-quarter (.75) inch stroke and four (4) inch height. Arrows of minimum one-half (1/2) inch stroke shall be used to indicate the location of the FDC.

MUELLER CENTURION  
KENNEDY MODEL K-81-A  
OR APPROVED EQUAL

NOTE: FIRE HYDRANT MUST BE PLUMB

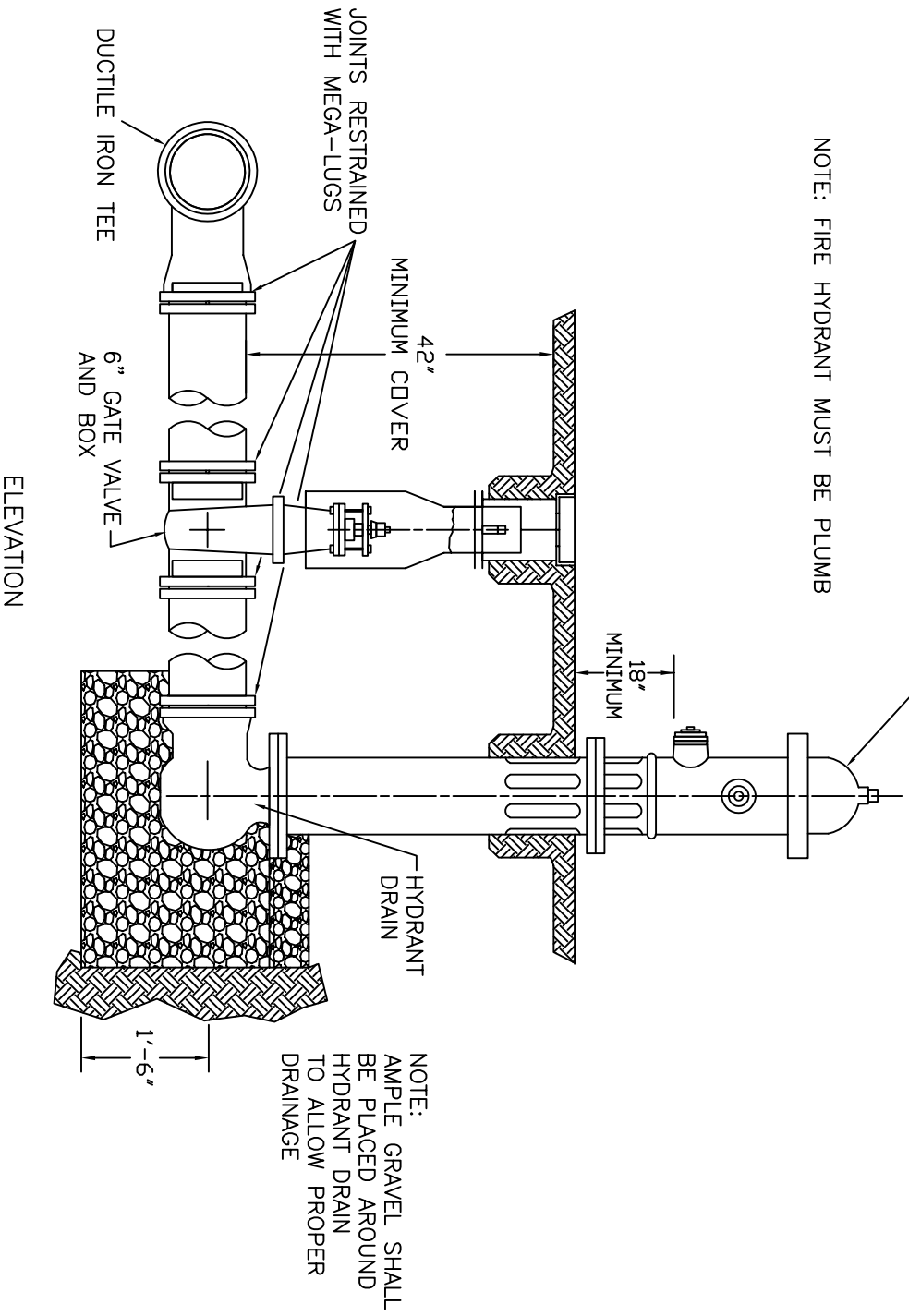

Detail No.  
350.01

FH-1



COUNTY OF  
PRINCE WILLIAM  
VIRGINIA

TYPICAL FIRE HYDRANT

Date  
7/15/14

Detail No.  
350.02

FH-2



COUNTY OF  
PRINCE WILLIAM  
VIRGINIA

TYPICAL FIRE HYDRANT  
LOCATION WITH CURB AND GUTTER  
OR DITCH LINE

Date  
7/15/14

NOTE:  
HYDRANT SHALL CONFORM IN ALL  
RESPECTS TO TYPICAL FIRE  
HYDRANT DETAIL

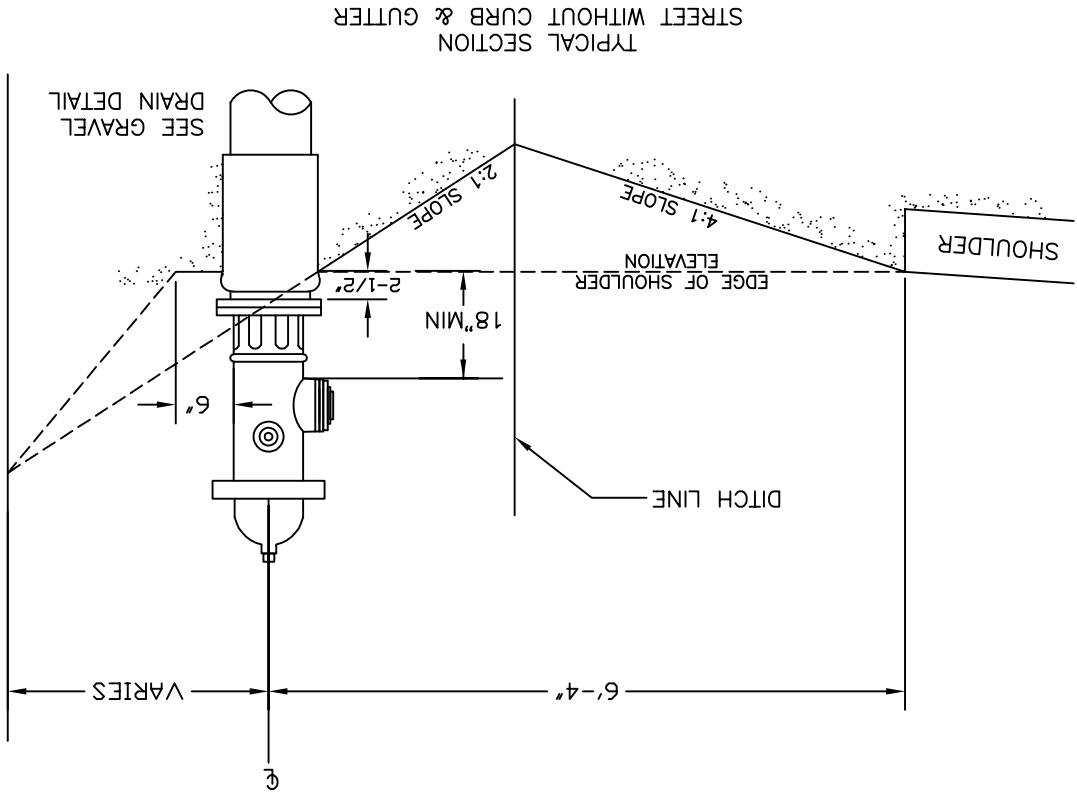
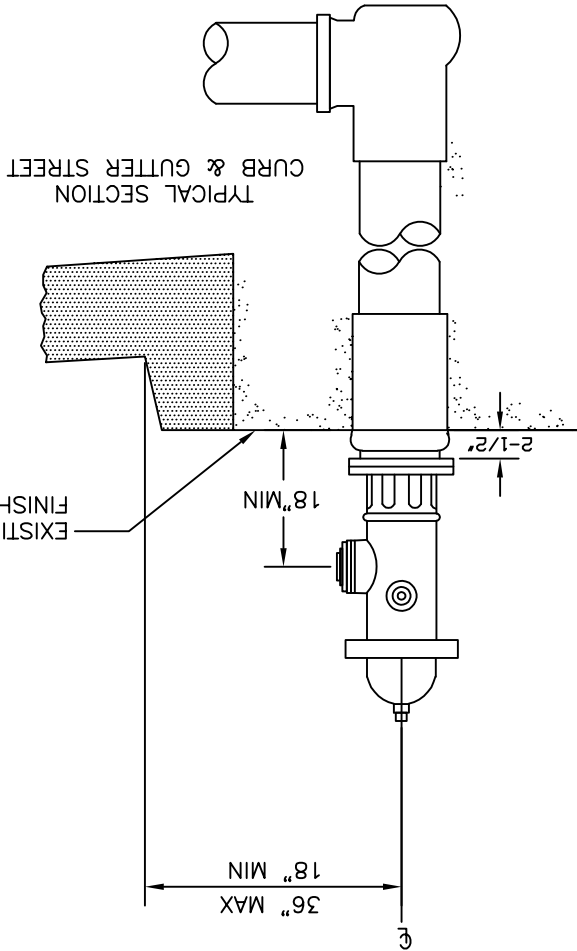

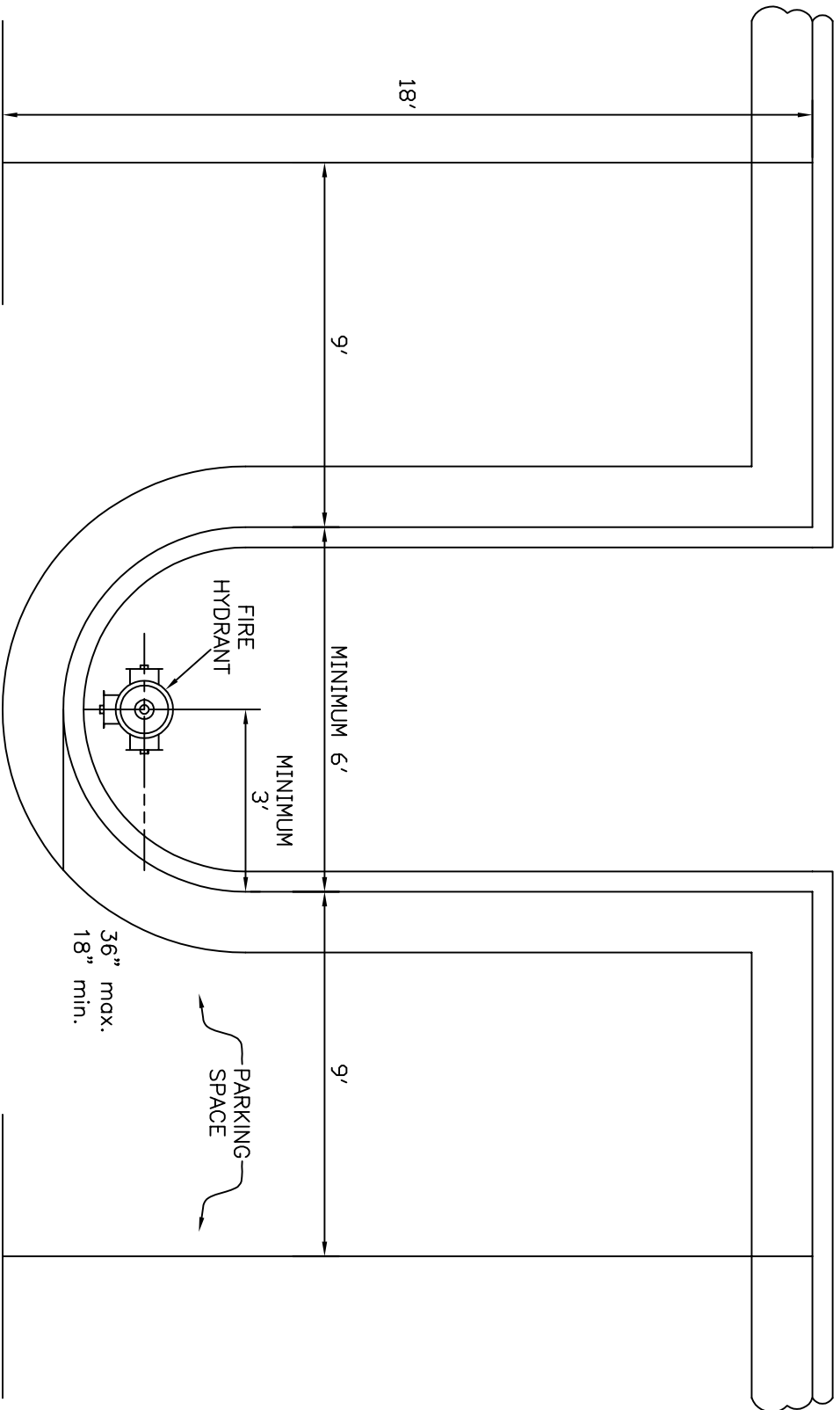

Detail No.

350.03

**FH-3**



COUNTY OF  
PRINCE WILLIAM  
VIRGINIA

TYPICAL FIRE HYDRANT LOCATION IN  
ISLAND & PARKING AREA

Date

7/15/14

4" Ø STEEL POSTS, PAINTED YELLOW  
 6' LONG, FILLED WITH CONCRETE  
 SET IN 3' OF CONCRETE  
 WITH 15" DIAMETER FOOTING

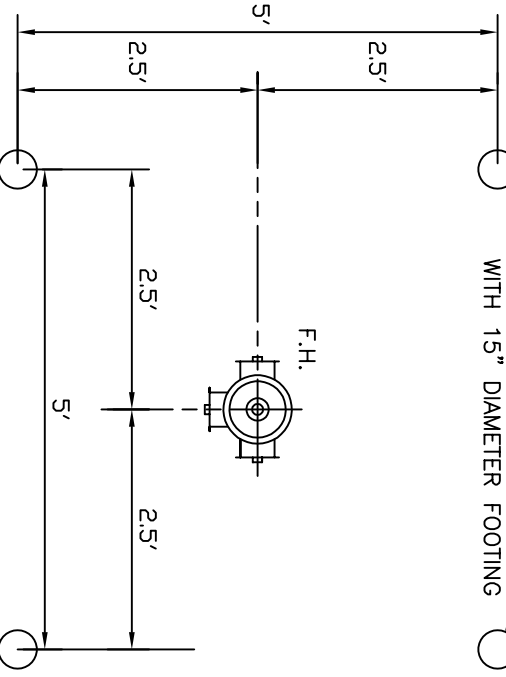

THIS AREA TO BE  
 DESIGNATED FIRE LANE AS  
 REQUIRED BY THE FIRE  
 MARSHAL

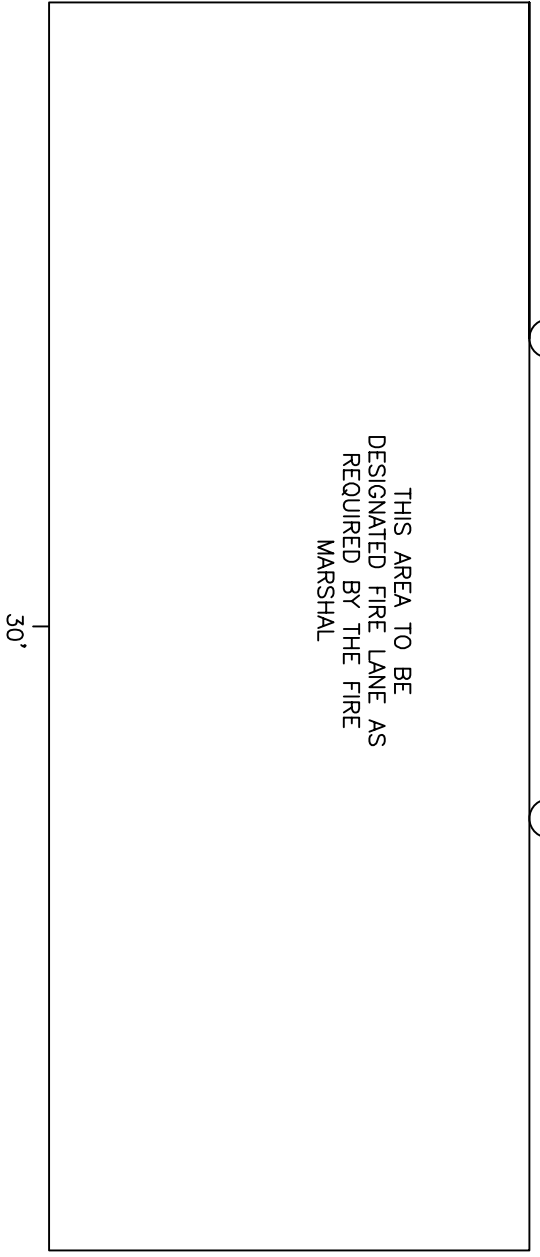

Detail No.

350.04

FH-4



COUNTY OF  
 PRINCE WILLIAM  
 VIRGINIA

TYPICAL FIRE HYDRANT VEHICLE  
 IMPACT PROTECTION

Date

7/15/14

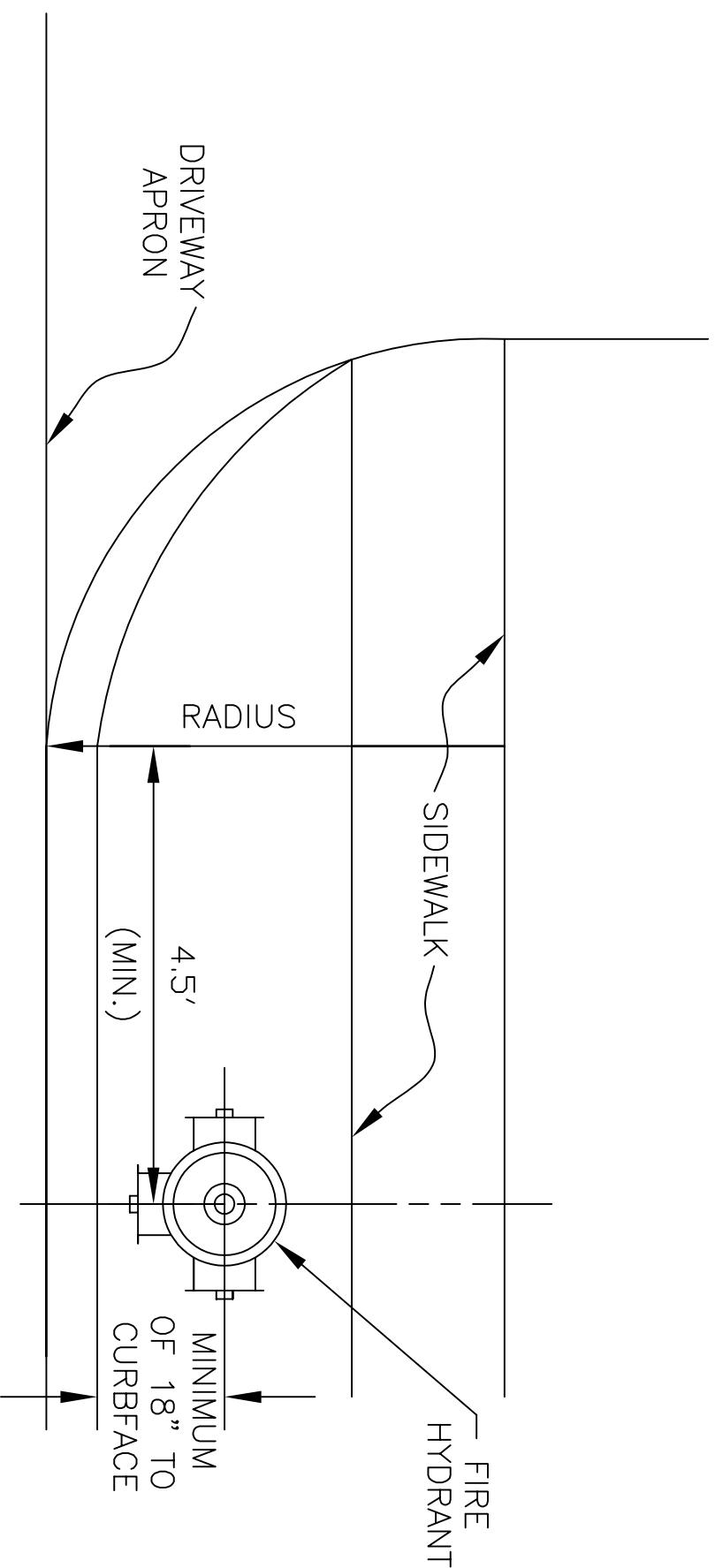

Detail No.

350.05

FH-5



COUNTY OF  
PRINCE WILLIAM  
VIRGINIA

TYPICAL FIRE HYDRANT LOCATION ON  
RESIDENTIAL STREET

Date

7/15/14



BUILDING FRONT  
NEAR MAIN ENTRANCE

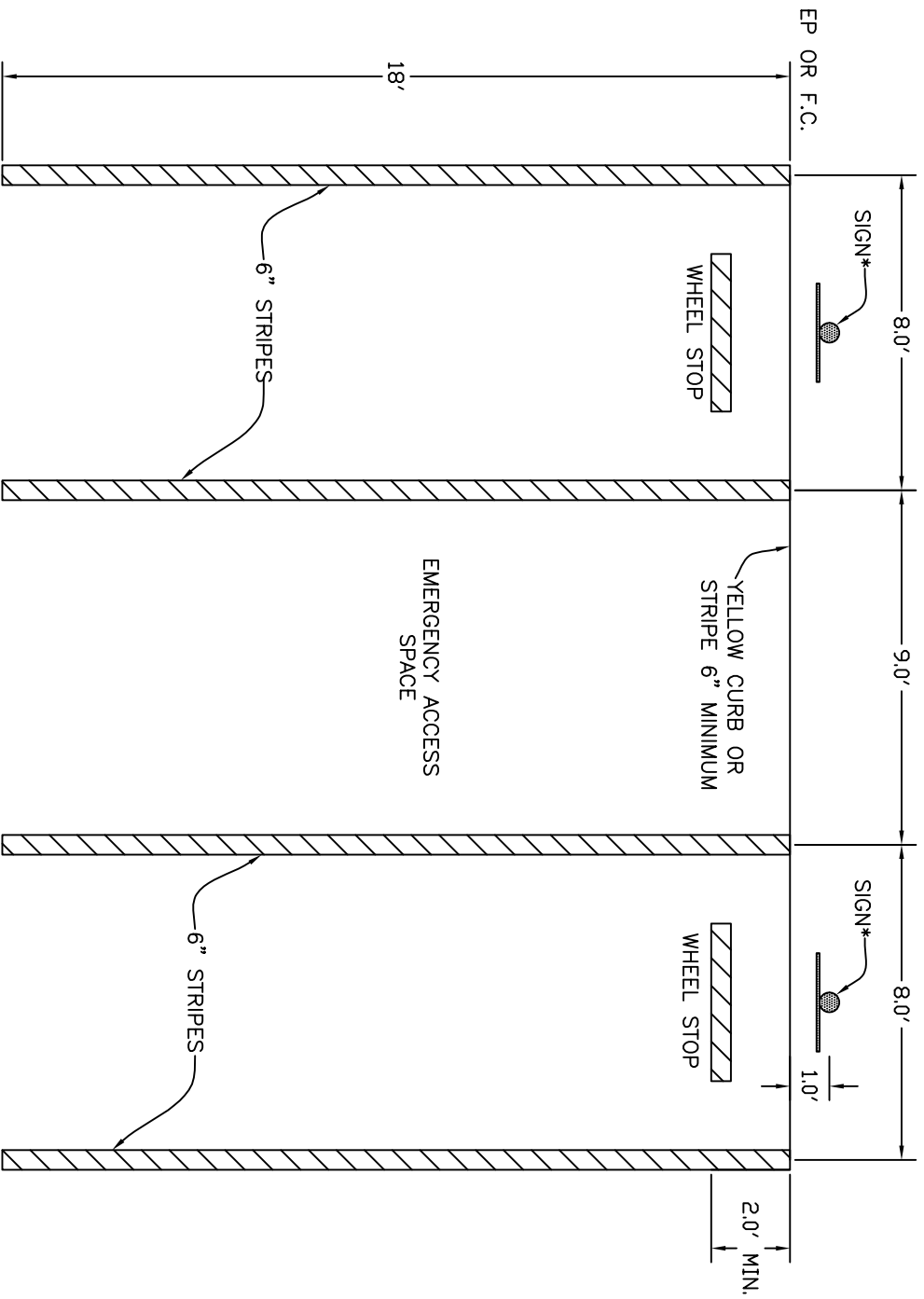

\*REFER TO HP-1 650.57 FOR SIGN DETAIL AND LOCATION  
NOTE: ACCESS RAMP MUST BE LOCATED AT SOME POINT  
ADJACENT TO THE 9.0' EMERGENCY ACCESS SPACE

Detail No.	EA-1		COUNTY OF PRINCE WILLIAM VIRGINIA	EMERGENCY ACCESS SPACE WITH ACCESSIBLE PARKING	Date
350.06					7/15/14

BUILDING FRONT  
NEAR MAIN ENTRANCE

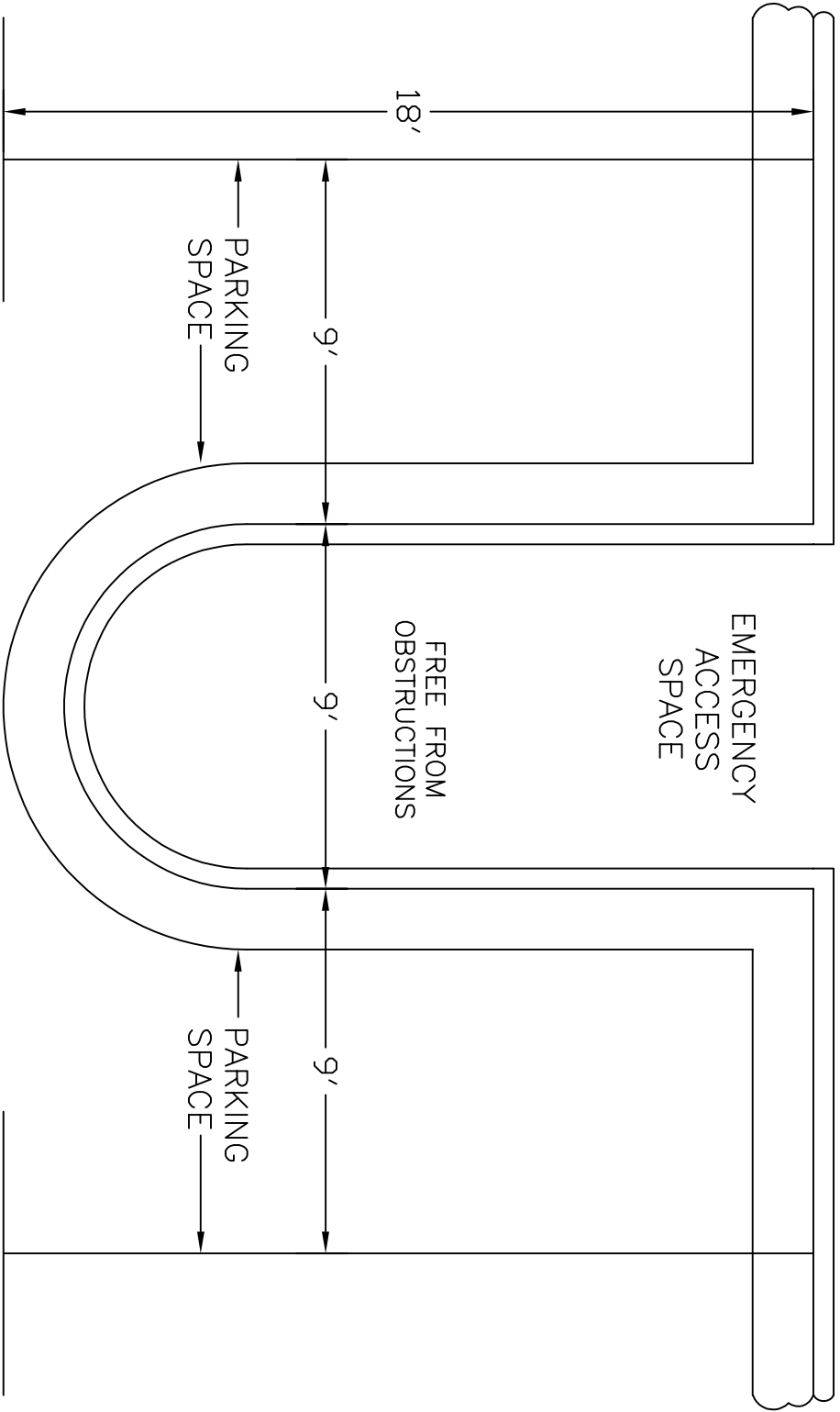

Detail No.

350.07

EA-2



COUNTY OF  
PRINCE WILLIAM  
VIRGINIA

TYPICAL EMERGENCY  
ACCESS SPACE

Date

7/15/14

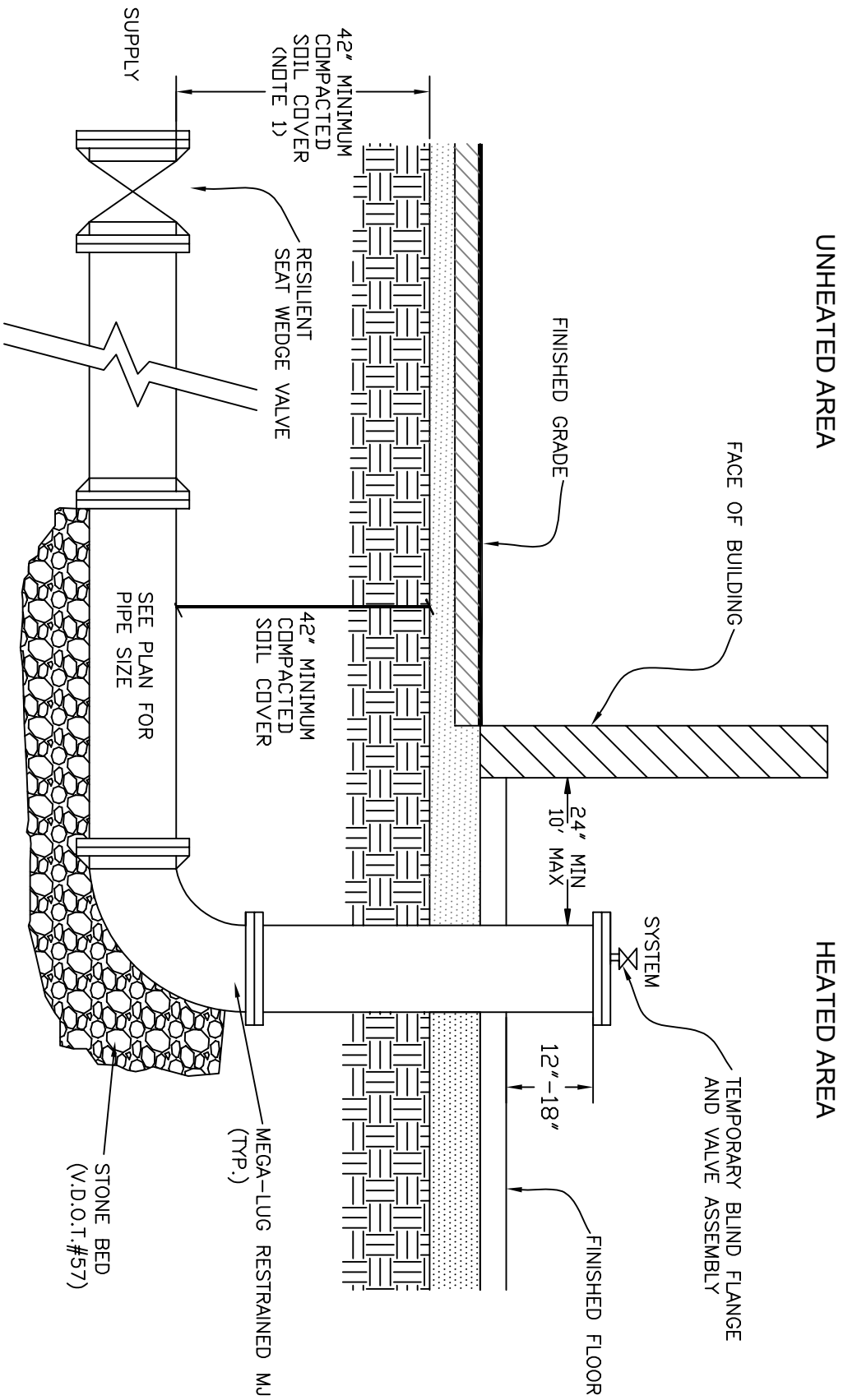

**NOTES**  
 1. FIRE LINE MAY HAVE LESS COVER AT CONNECTION POINT TO THE PUBLIC WATER SUPPLY.

Detail No.	<b>FL-1</b>		COUNTY OF PRINCE WILLIAM VIRGINIA	FIRE LINE DETAIL	Date
<b>350.08</b>					10/3/17

**SITUATION A**

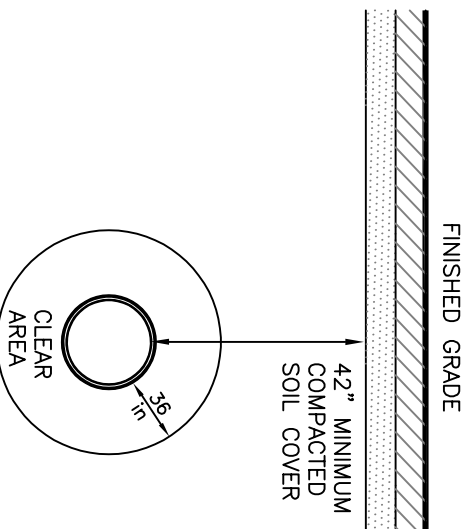

NOTES:  
 1. PROVIDE SUPPLEMENTARY INSULATING MEASURE IF:

- <42" OF SOIL COVER IS PROVIDED (NOTE: A MINIMUM 36" DEPTH OF COVER MUST BE MAINTAINED.)
- ANY UTILITY OR NON-SOIL FILL MATERIAL IS PLACED WITHIN THE CLEAR AREA

**SITUATION B**

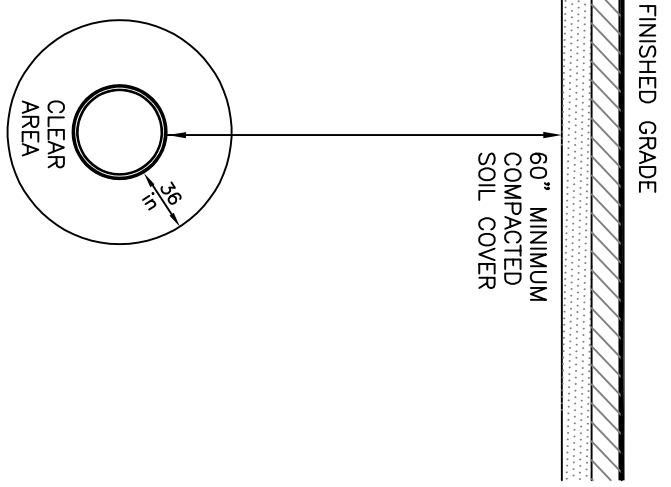

NOTES:  
 1. PROVIDE SUPPLEMENTARY INSULATING MEASURE IF:

- STORM OR ROOF DRAIN IS PLACED WITHIN THE CLEAR AREA

Detail No.

350.09

FL-2



COUNTY OF  
 PRINCE WILLIAM  
 VIRGINIA

FIRE LINE DETAIL

Date

3/31/17

TOP OF VAULT (SEE VAULT DETAIL)

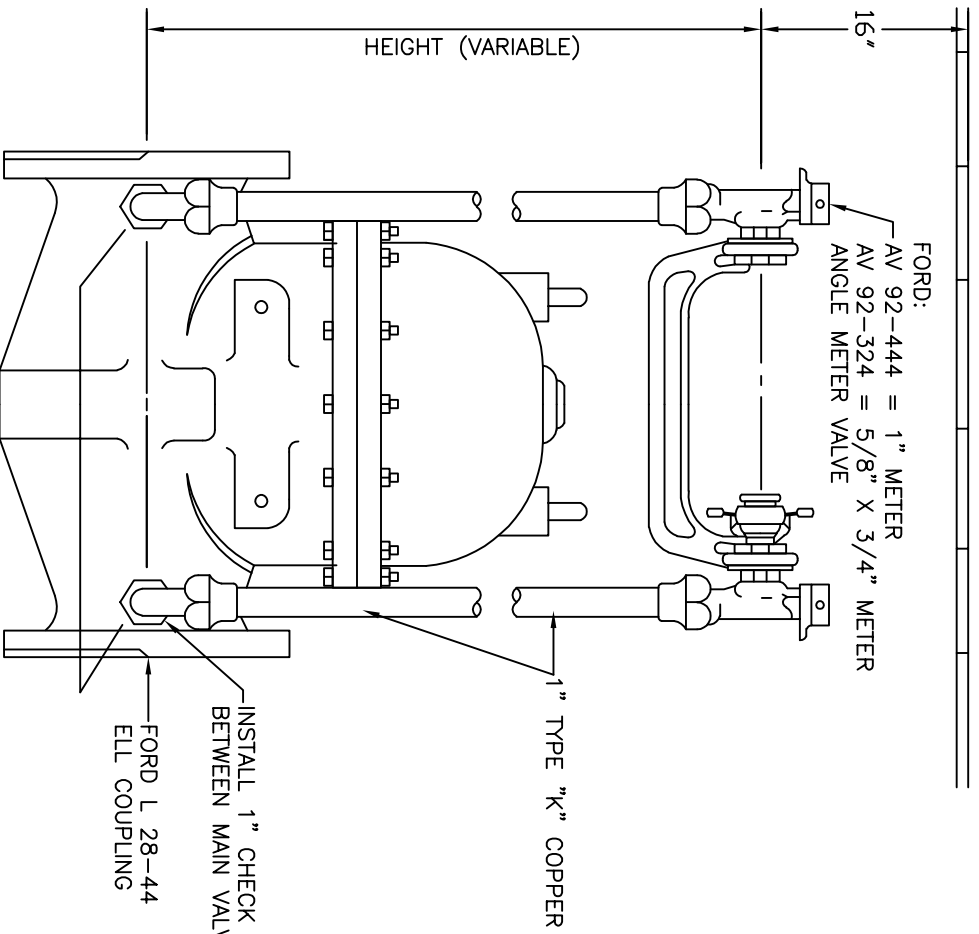

NOTES:

1. PROVIDE 1" READING LID IN TOP OF VAULT DIRECTLY OVER METER DIAL.
2. METER TO BE OBTAINED FROM PWCSA.
3. GATE VALVE TO BE INSTALLED ON EITHER SIDE OF DETECTOR CHECK VALVE.

Detail No.

350.10

DCV-1



COUNTY OF  
PRINCE WILLIAM  
VIRGINIA

WATER DISTRIBUTION SYSTEM  
DETECTOR CHECK VALVE WITH  
1", 5/8" & 3/4" DETECTOR METERS

Date

7/15/14

2'-6" TOP OPENING FOR MANHOLE  
 FRAME & COVER WITH AN 11" READING LID

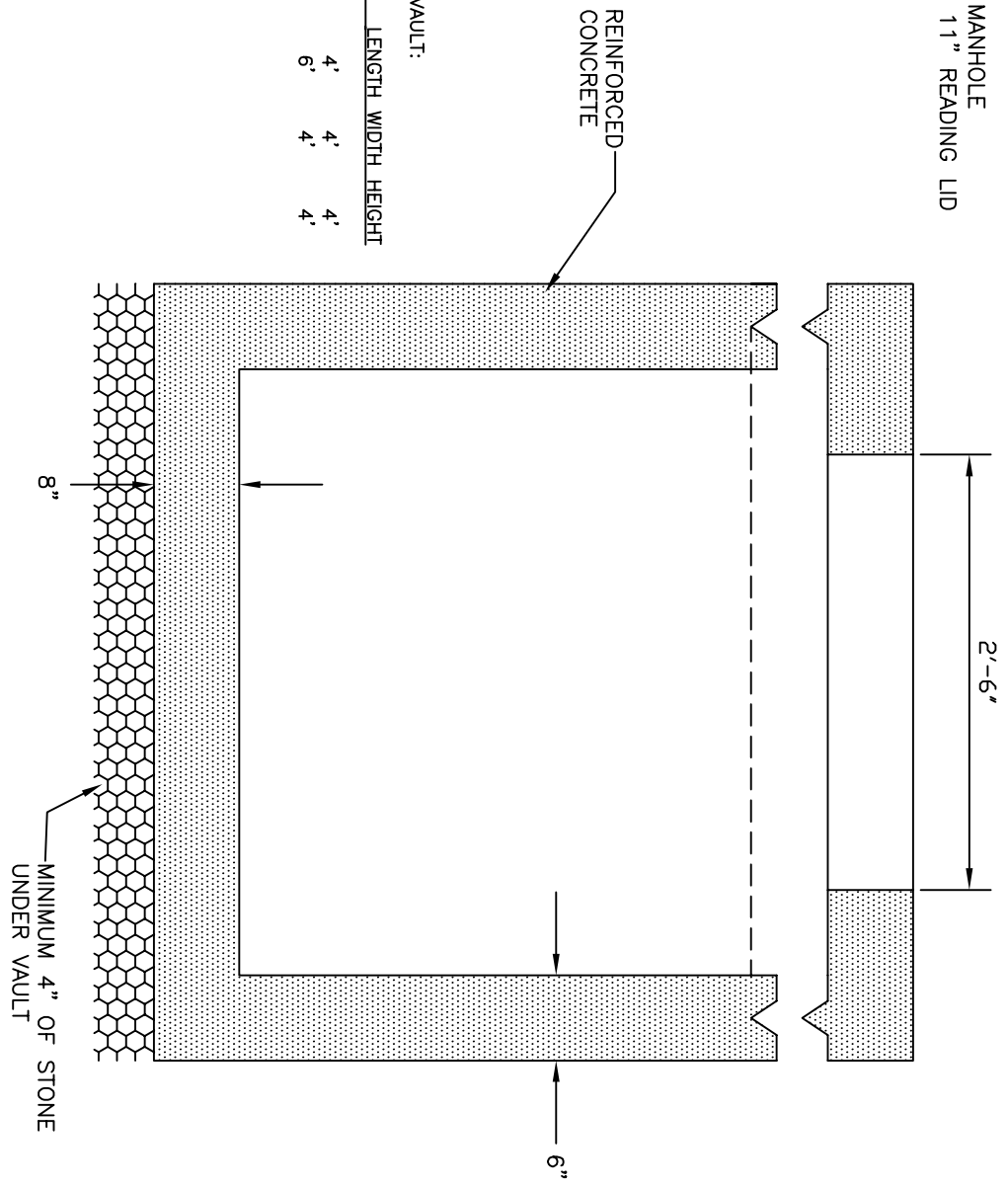

Detail No.  
 350.20

DCV-2



COUNTY OF  
 PRINCE WILLIAM  
 VIRGINIA

DETECTOR CHECK VALVE VAULT  
 CROSS-SECTIONAL VIEW

Date  
 7/15/14

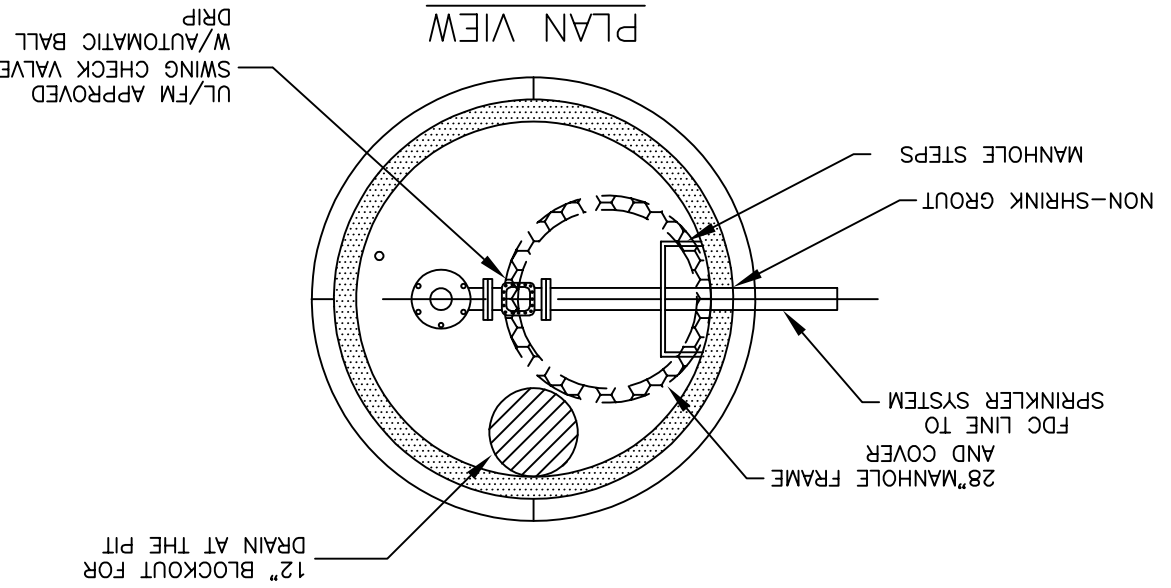
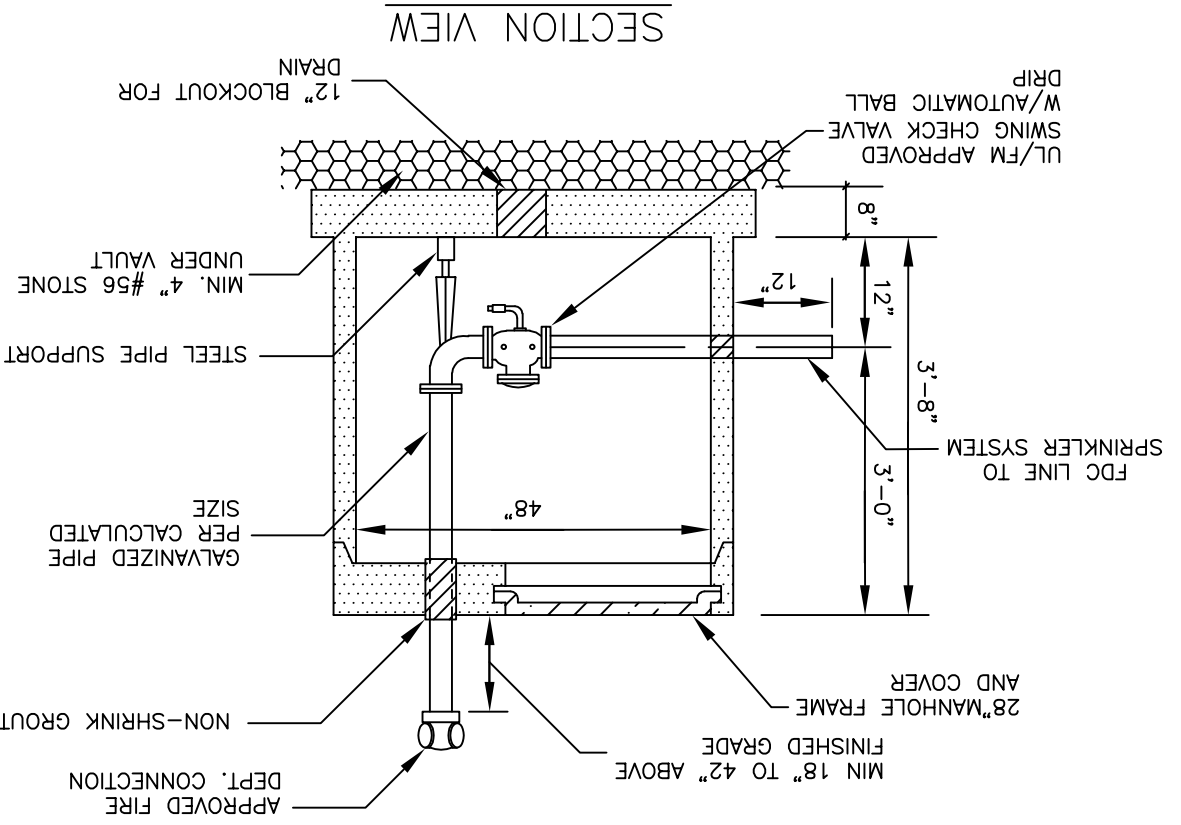

SECTION VIEW

PLAN VIEW

Detail No.  
350.21

VLT-1



COUNTY OF  
PRINCE WILLIAM  
VIRGINIA

TYPICAL FIRE DEPARTMENT CONNECTION  
VAULT  
(4' DIAMETER)

NTS  
Date  
1/21/18

FIRE DEPARTMENT CONNECTION

THE HEIGHT OF CONNECTION SHALL BE BETWEEN 18" TO 42" BETWEEN THE FINISHED GRADE AND THE CENTERLINE OF THE FDC

2'-6" TOP OPENING FOR MANHOLE THE FRAME & COVER WITH AN 11" READING LID

SPRINKLER/STANDPIPE IDENTIFICATION PLATE

CONNECTION TO SPRINKLER SYSTEMS CHECK VALVE

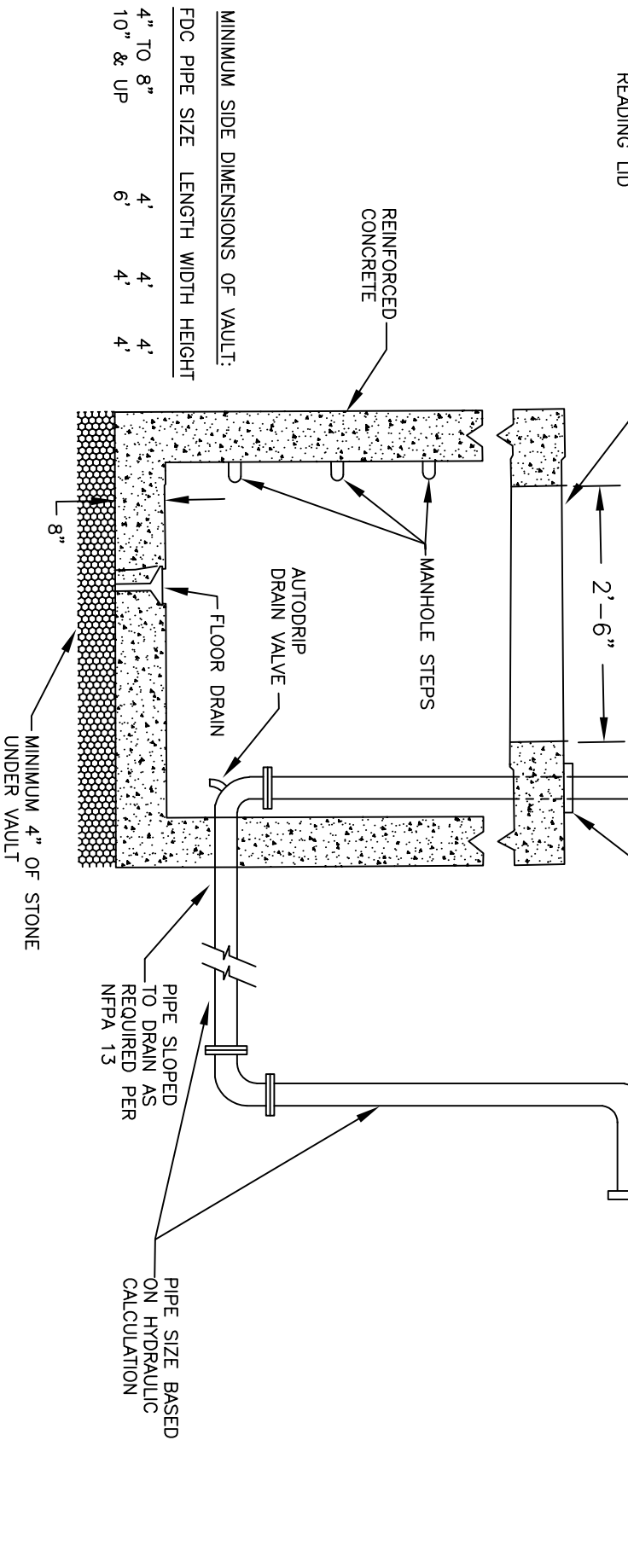

MINIMUM SIDE DIMENSIONS OF VAULT:

FDC PIPE SIZE	LENGTH	WIDTH	HEIGHT
4" TO 8"	4'	4'	4'
10" & UP	6'	4'	4'

Detail No.  
350.22

FDC-1



COUNTY OF PRINCE WILLIAM VIRGINIA

TYPICAL REMOTE FIRE DEPARTMENT CONNECTION DETAIL

Date  
1/21/18



Detail No.  
350.30

ST-2



COUNTY OF  
PRINCE WILLIAM  
VIRGINIA

METHOD OF STRAPPING FIRE  
HYDRANT TO MAIN

Date  
7/15/14

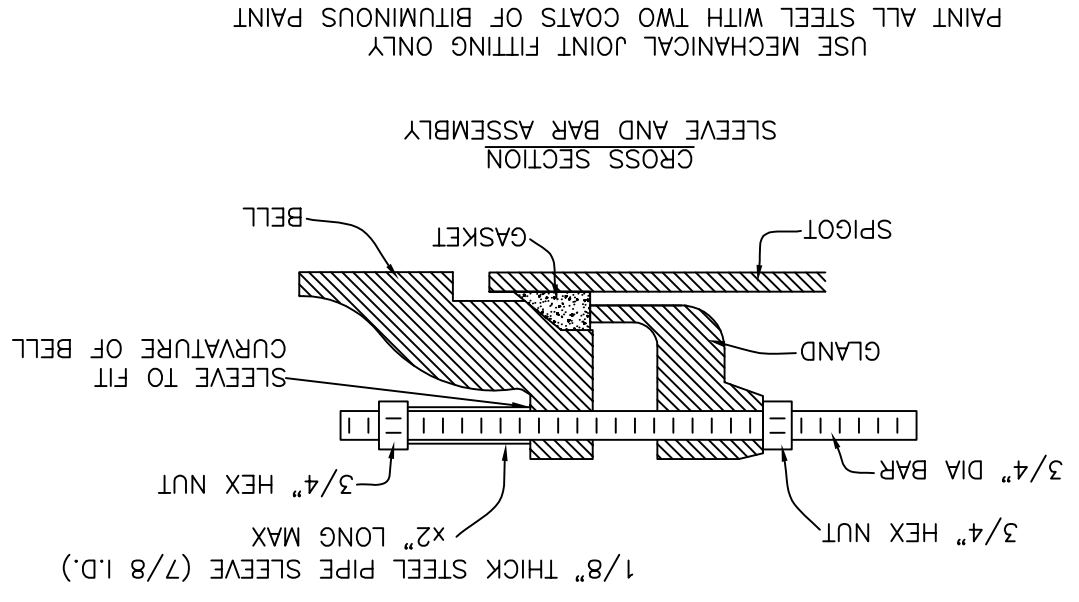

USE MECHANICAL JOINT FITTING ONLY  
PAINT ALL STEEL WITH TWO COATS OF BITUMINOUS PAINT

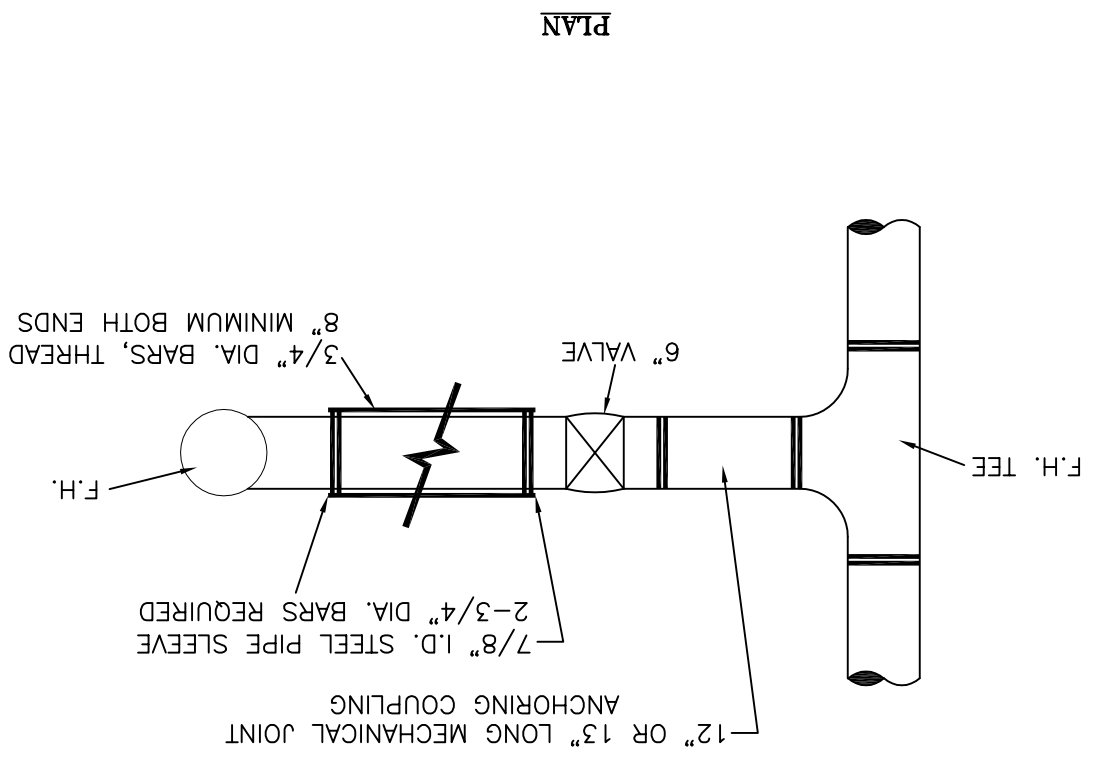

USE MECHANICAL JOINT FITTINGS ONLY  
 PAINT ALL STEEL WITH TWO COATS OF BITUMINOUS PAINT

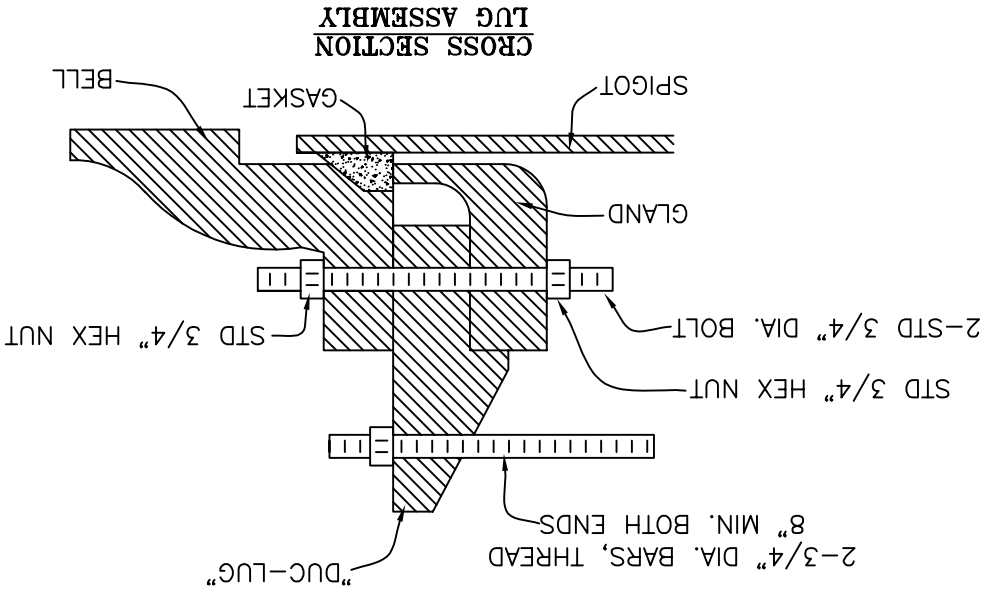

PLAN

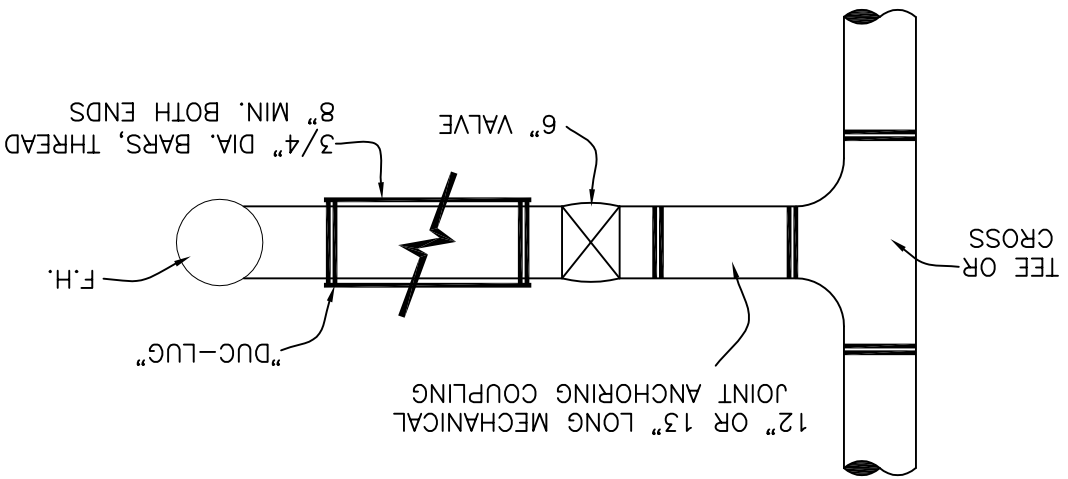

Detail No.

350.40

DL-1



COUNTY OF  
 PRINCE WILLIAM  
 VIRGINIA

ALTERNATE METHOD OF STRAPPING  
 VALVE TO HYDRANTS WITH "DUC-LUGS"

Date

7/15/14